

Motor Controller

MP72 MP128

Manual

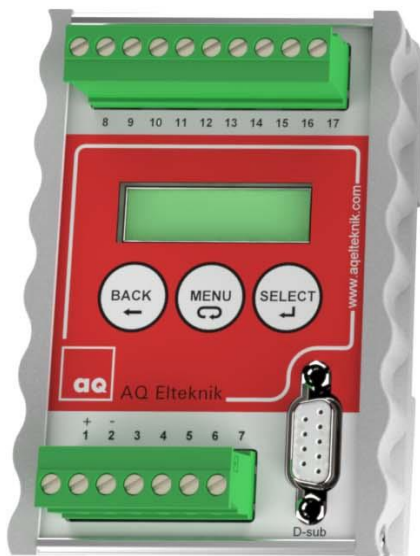

Motor Controller

MP72 MP128

- **Manual version: 2.22**
- **Program version: 2.1x**
- **MP720C63.gsd (gsd-file) version: 1.0**

April 2020

AQ M-Tech AB

Table of contents

1. Manufacturer information.....	4
Version	4
Manufacturer Declaration of Conformity.....	4
Limited Warranty	4
Warning	4
Manufacturer Information	4
Certificate of Quality and Function	4
2. Introduction	5
Installing the Motor Controller MP72	5
Installing the Motor Controller MP128	6
3. Using the Motor Controller.....	7
Start-screen	7
MIXER Run-Stop	7
MIXER SPEED	7
SHOW DATA.....	7
SETTINGS.....	7
4. COMMUNICATION = 4–20mA.....	8
5. COMMUNICATION = PROFIBUS	9
Connecting Profibus	9
PROFIBUS Parameters	9
Profibus Status-symbol	9
Request Data and Response Data.....	9
Request Data table.....	10
Response Data table.....	10
TROUBLESHOOTING	11
6. Technical specifications.....	12

1. Manufacturer information

AQ M-Tech AB operates a policy of on-going development and reserves the right to make changes and improvements to any of the products described in this manual without prior notice.

Under no circumstances shall AQ M-Tech be held responsible for any loss or indirect damage howsoever caused. The contents of this document are provided as it is. AQ M-Tech AB reserves the right to revise this document or withdraw it at any time without prior notice.

Version

It is important that the manual version and the gsd-file version agree with the software version of Motor Controller. See page 2 for the versions. This manual and the gsd-file can be downloaded at www.aqotech.se

The software version of MP72 is shown briefly on the display when power is switched on.

Manufacturer Declaration of Conformity

Manufacturer: AQ M-Tech AB Sweden declares, that the product:

Motor Controller marked with CE-label conforms with the following standards: EN 61000-6-2, EN 61000-6-4, EN55011 (Group 1, Class B).

Motor Controller marked with  conforms to WEEE directive 2012/19/EU. The Motor Controller also conforms to RoHS directive (EU) 2015/863. When the Motor Controller is to be discarded, send it back to AQ M-Tech AB for safe disposal. WEEE directive 2012/19/EU.

Limited Warranty

AQ M-Tech AB warrants to the original end user that the Motor Controller is free from any defects in materials or workmanship for a period of one year from the date of purchase. During the warranty period, should the Motor Controller have indications of failure due to faulty workmanship or materials, AQ M-Tech AB will replace it with no charge. This warranty shall not apply if the Motor Controller is modified, misused or subjected to abnormal working conditions.

Replacement as provided under this warranty is the only remedy of the purchaser. The purchaser pays freight to AQ M-Tech AB. AQ M-Tech AB shall in no event be held liable for indirect or consequential damages of any kind or character to the purchaser. See "Manufacturer Information" for address.

Warning

The Motor Controller is intended to be used with brushless DC motors with Hall sensors and the Dynamic Mixer DM50 manufactured by AQ M-Tech AB. AQ M-Tech AB takes no responsibility for any possible damage that could happen if any other motor not conforming to the specifications is connected to the Motor Controller.

Manufacturer Information

Manufacturer Address:

AQ M-Tech AB

Bolandsgatan 10
SE-753 23 Uppsala

Sweden

Telephone: +46 18 470 29 00

Website: www.aqotech.se

E-mail: Info.aqotech@aqg.se

Certificate of Quality and Function

AQ M-Tech AB guaranties that the Motor Controller MP72 has passed function tests and quality tests.

2. Introduction

Motor Controller is used to control the Dynamic Mixer DM50 or other BLDC motors. Motor Controller is intended for industrial use only and is not approved for use in explosive area.

Installing the Motor Controller MP72

The Motor Controller MP72 should be installed where it is protected from dust and water. It is made to be attached to a DIN-rail, to which it snaps easily and can be removed by pushing up and bending the top out. The connector terminals 1-7 and 8-17 can be removed by pulling the connector out. Profibus is connected to the Profibus DP (D-sub) connector, see chapter 8: Connecting Profibus.

The Motor Controller MP72 should be installed in accordance with national regulations. A person with the required knowledge should perform the installation.

MP72 should be connected to a 24V power supply with sufficient power output.

Minus of the power supply (24V MINUS) should be connected to the system ground if possible. Voltage on the power inputs should not exceed 35V relative ground.

The cable between Motor Controller MP72 and the motor must be shielded.

Motor Controller MP72 contains an inverter controlling the speed of the motor. The motor winding and hall sensors must be connected correctly in order for the motor to function correctly. If wrongly connected the motor will draw high current, vibrate or not run at all. The wires to hall sensors A, B and C are sensitive to radiation and should not be adjacent to any of the three cables connected to the motor windings within the cable.

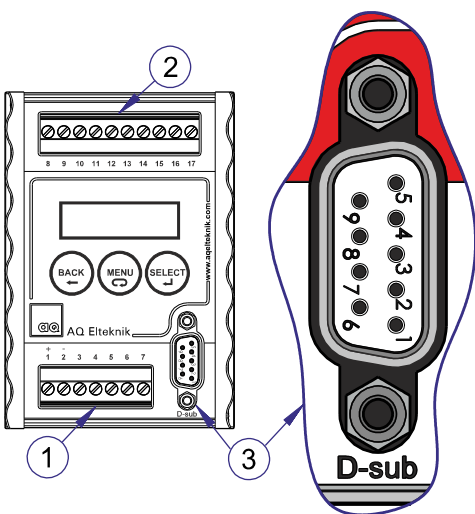

- 1 Terminal
- 2 Terminal (for Sensors)
- 3 D-sub

MP72 Connector Terminal	Connections to terminal	Data
1	+ power PLUS	24VDC
2	- power MINUS	0V
3	Run input (active low)	0V or 3,3V
4	(Input not used)	0V or 3,3V
5	Stop input (active low)	0V or 3,3V
6	+ 4-20 mA	Max 22mA
7	- power MINUS	0V for inputs
D-sub 1	Cable shield	
D-sub 2		
D-sub 3	Profibus Cable B Green (-)	
D-sub 4		
D-sub 5	- 0V (for terminating resistor)	
D-sub 6	+ 5V (for terminating resistor)	
D-sub 7		
D-sub 8	Profibus Cable A Red (+)	
D-sub 9		

MP72 Connector Terminal	Colour of DM50 mixer cables connected to MP72 Terminal	Connections to a brushless DC motor
8	White	Motor winding A
9	Brown	Motor winding B
10	Green	Motor winding C
11	Yellow	Hall sensor -0V
12	Grey	Hall sensor A
13	Pink	Hall sensor B
14	Blue	Hall sensor C
15	Red	Hall sensor +5V
16	Shield	Shield
17		

Installing the Motor Controller MP128

The Ultrasound Controller MP128 is protected according to IP65 and can be installed outside a protecting cabinet. The bottom plate must be removed (8 screws) in order to access the terminals to connect the cables. Remove dummy coverings and insert cable glands as many as needed. There are 3 small and 4 big cable glands, see page 6. There should be only one cable in each cable gland to achieve IP65 protection. The pressure compensation element can be moved but must not be removed. Make sure the gasket is in place when screwing the bottom plate.

The Motor Controller should be installed in accordance with national regulations. A person with the required knowledge should perform the installation.



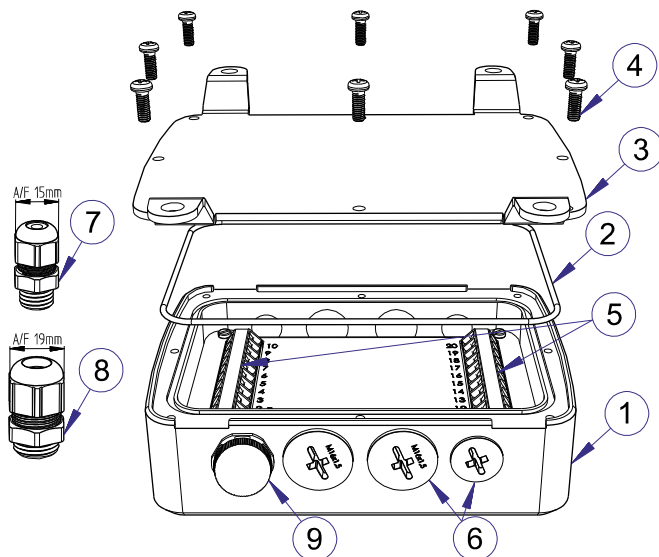

Terminal number	Description	Data
1	+ power PLUS	24VDC
2	- power MINUS	0V
3	Run input (active low)	0V or 3,3V
4	(Input not used)	0V or 3,3V
5	Stop input (active low)	0V or 3,3V
6	+ 4-20 mA	Max 22mA
7	- power MINUS	0V for inputs; 0V for terminating resistor Profibus
8	Profibus Cable A (+)	Red
9	Profibus Cable B (-)	Green
10	+5V (for termination)	+5V for terminating resistor Profibus

Terminal number	Colour of DM50 mixer cables connected to MP128 Terminal	Data
11	White	Motor winding A
12	Brown	Motor winding B
13	Green	Motor winding C
14	Yellow	Hall sensor -0V
15	Grey	Hall sensor A
16	Pink	Hall sensor B
17	Blue	Hall sensor C
18	Red	Hall sensor +5V
19	Shield	Shield
20		



- 1 Enclosure
- 2 Gasket
- 3 Bottom plate
- 4 Screws
- 5 Terminals
- 6 Dummy coverings
- 7&8 Cable glands (small and big)
- 9 Pressure compensation element

3. Using the Motor Controller

<p>Toggle between standby and power-on. (MP128 only)</p> 	<p>Go BACK previous menu-level or cancel a Selected operation</p> 	<p>Scroll through the MENU or Scroll trough a list of parameter-values</p> 	<p>SELECT a menu or Confirm the selection of a parameter-value</p> 
--	---	--	--

Keep MENU pressed to scroll continuous through parameter values. Press BACK while pressing MENU to scroll backwards.

Start-screen

As soon as the power is applied to the Motor Controller, it starts displaying the program revision on the LCD-display, quickly followed by the start-screen. The start-screen shows MP72/MP128 on the first line and on the second line it shows to the left:

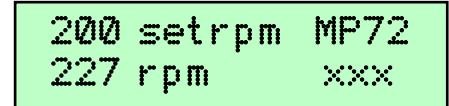

```
200 setrpm
227 rpm
Not Calibrated
Cal Error
Error x
xxx
```

The set speed is 200 rpm.
 Motor is running with the speed of 227 rpm
 Calibration must be done.
 Error has been detected during calibration. Calibration must be done again.
 Error. X is the error number, see troubleshooting.
 If profibus communication is enabled there is a Profibus status-symbol here. If 4-20mA communication is selected it says 4-20mA here.

MIXER Run-Stop

In “MIXER Run-Stop” menu the mixer motor can be started and stopped. At power off “MIXER Run-Stop” will be reset to Stop. If Profibus is enabled it will take control.

MIXER SPEED

In “MIXER SPEED” menu the Mixer SetSpeed can be set. But if Profibus is enabled it will take control. Maximum speed is 1000rpm. (Profibus parameter Maximum Speed is ignored). Lowest speed is 25rpm. If speed is set lower than 25rpm motor will stop.

SHOW DATA

In the SHOW DATA-menu various measured data can be seen: Power supply voltage, Motor voltage, Motor Current and Hall sensors.

Select “ErrorCode” To show Error Codes: 01= overcurrent due to short circuit. 02= Motor is stuck. 03= Calibration error 04= Hall element error during calibration 05= Hall element error 06= Power supply voltage is lower than 18V.

SETTINGS

Trough the SETTINGS-menu the parameters of the Motor Controller can be set.

Select “CALIBRATION”: to calibrate the motor. Calibration minimizes motor power consumption and improve smooth rotation. The Motor Controller is shipped uncalibrated and calibration must be done before use. Also if the motor or Motor Controller has been replaced, calibration must be done again.

IMPORTANT: Calibration must be done with the motor free running and completely unloaded. The mixer must be removed from container and the stirrer must be pulled out. Only then calibration can be done successfully. During calibration the motor rotates slowly ½ rotation.

Select “COMMUNICATION”: to set it to DISABLE (all communication only via menu), PROFIBUS (enables communication via Profibus), or 4-20mA (Speed via 4-20mA, Run/Stop via Run and Stop input or via menu)

Select “PROFIBUS ADDRESS”: to set the profibus address (0-126). It must be a unique address.

Select “RESTORE settings”: to restore all settings and calibrations to factory default value.

4. COMMUNICATION = 4–20mA

The value of setrpm is controlled by the current on the 4–20mA input.

The 4-20mA input (terminal 6) measures current to ground (terminal 7) via a 100 ohm resistor.

At 4mA setrpm is 0 rpm

At 20mA setrpm is 1000 rpm.

The digital inputs are terminal 3 (Run), terminal 4 (not used) and terminal 5 (Stop).

The digital inputs has an internal connection to 3,3V via a 1 kΩ resistor.

Digital inputs are activated by connecting them to ground (terminal 7) via a relay, switch or transistor.

In the table High means free input, or input voltage >3V (max 6V)

Low means connected to 0V or input voltage < 0,5V (min -0,5V)

X means it is either High or Low.

Pulse is a low pulse min 20ms.

Run Terminal 3	Not used Terminal 4	Stop Terminal 5	Motor previous status	Motor next status
High	x	x	Stop	No change
x	x	High	Run	No change
High	x	Pulse low	Run or Stop	Stop
Pulse low	x	High	Run or Stop	Run
x	x	Low	Run or Stop	Stop

5. COMMUNICATION = PROFIBUS

The Motor Controller supports Profibus DP-V0 with communication speeds up to 12 Mbit/s.

Connecting Profibus

The Profibus cable connects to MP72 via a Profibus 9-pin D-sub connector see table page 5.

The Profibus cable connects to MP128 via terminals see table page 6.

If the Profibus cable is to be terminated in the MP128:

Put 390Ω between terminal 8 and 10.

Put 390Ω between terminal 7 and 9.

Put 220Ω between terminal 7 and 10.

The Profibus-interface in Motor Controller is not isolated from power.

The gsd-file: MP720B0E.gsd is needed for configuration of the Profibus master. It can be downloaded at www.aqmtech.se The version of the gsd-file is written in the beginning of the gsd-file (the gsd-file can be viewed with a text editor). It must be the correct version. See page 2 for correct version.

PROFIBUS Parameters

See **SETTINGS**.

Profibus Status-symbol

The current status of the Profibus communication is shown with a Profibus status-symbol on the start screen at the bottom right corner of the display:

Blank	= Profibus is not enabled.
□	= Bitrate has not been detected.
■	= Profibus communication has been detected and bitrate has been set.
P	= Parameter or configuration telegram has been received.
e	= Parameter or configuration telegram error.
> <	= (alternating) Data exchange telegrams are received and responded to.
X	= Ready for data exchange but no telegram is received.
C	= Has been ready for data exchange but is not ready anymore.

Request Data and Response Data

The master sends 3 byte Request Data to Motor Controller which responds with 6 bytes Response Data (1-6). See table.

When Profibus is enabled SetSpeed is controlled by Profibus. By disabling Profibus, SetSpeed can be controlled via the menu.

Request Data table

Request Data	
1	Control bits bit0: 1 = Run 0 = Stop bit1: bit2: bit3: bit4: bit5: bit6: bit7:
2	SetSpeed High byte (rpm)
3	SetSpeed Low byte (rpm)

Response Data table

Response Data	
1	Error bits bit0: 1= Motor should rotate but it does not. bit1: 1= ActualSpeed is not within SetSpeed \pm 25% bit2: bit3: 1= Motor encoder error bit4: 1= Motor current has been limited. bit5: 1= Calibration error or calibration never done bit6: bit7:
2	ActualSpeed High byte (rpm)
3	ActualSpeed Low byte (rpm)
4	Motor current (1/10 A)
5	Power Supply Voltage (V)
6	Power Consumption (W)

TROUBLESHOOTING

Not Calibrated is shown on start-screen if the motor has not been calibrated. Calibration should be performed. Error messages are shown both on start-screen and in SHOW DATA.

Error 1 Overcurrent protection. Motor Controller detected too high current. Possible reason: short circuit.

Error 2 Motor does not rotate although it should. Possible reason: Bad connection, too high rotation-resistance.

Error 3 Motor does not rotate as it should during calibration.

Error 4 Motor hall sensor error during calibration

Error 5 Motor hall sensor error. Possible reason: Bad connection or faulty hall sensor or faulty Motor Controller.

Error 6 Power supply voltage has been below 17V for more than one second. The motor stopped if it was running. Possible reason: Power supply fault.

To reset the error messages (1-6), either power off Motor Controller, or start and stop the motor.

Calibration error: Possible reason: Too high rotation-resistance. Wrong order of hall sensors. Hall sensor not connected. Hall sensor failure. If the motor does not rotate at all during calibration (1/2 rotation), possible reason is bad connection or faulty motor or faulty Motor Controller. Calibration error message will be reset by performing a new calibration.

Profibus status-symbol

“SETTINGS ♦ COMMUNICATION” must be set to Profibus to show the profibus status-symbol.

If the Profibus status-symbol shows all the time: Motor Controller detects no communication. Profibus cable is not connected or has wrong polarity.

If the Profibus status-symbol shows all the time: Motor Controller detects communication but the address could be wrong.

If the Profibus status-symbol shows **P** and **e** repeatedly it means the profibus master sends parameter or configuration but MP72 thinks they are wrong so the profibus master sends them again.

If the Profibus status-symbol shows **C** it means Motor Controller has once been ready for data but is not ready anymore. A reason can be communication error or wrong number of bytes in request data.

If the Profibus status-symbol shows **X** it is ready for data but it receives no data.

Error bits in Profibus Response Data 1

bit0: 1= Motor should rotate but it does not. Possible reason: see Error 2 above.

bit1: 1= ActualSpeed is not within SetSpeed \pm 25%. Possible reason: load is too heavy. Reduce speed.

bit3: 1= Motor hall sensor error. Possible reason: see Error 5 above.

bit4: 1= Motor current has been limited. Possible reason: load is too heavy.

bit5: 1= Calibration has not been done or has been done with error. Calibration should be performed.

6. Technical specifications

Weight	210g (MP72), 370g (MP128)
Operating temperature	0°C to 50°C
External Power Supply voltage	24V \pm 4V DC
Current consumption max	2 A with DM50 at 1000 rpm
Max output current	5 A
Max output power	40W with DM50 at 1000 rpm
Connects to	Brushless DC motors with Hall sensors, example: DM50
Digital inputs terminal 3,4,5	Min -0,5V Max +6V Active low (internal 1k Ω to +3,3V)
Analog input 4-20mA	Input resistance 150 Ω , max 22mA
Protection class	IP30 (MP72), IP65 (MP128)
Ambient Humidity	0% - 90%
Material	Aluminium, PA, PC, POM
Profibus DP	DP-V0, Max bitrate 12 Mbit/s

Cable size for cable glands in MP128 small (M12): \varnothing 3,5mm - \varnothing 7mm big (M16): \varnothing 4,1mm - \varnothing 10mm

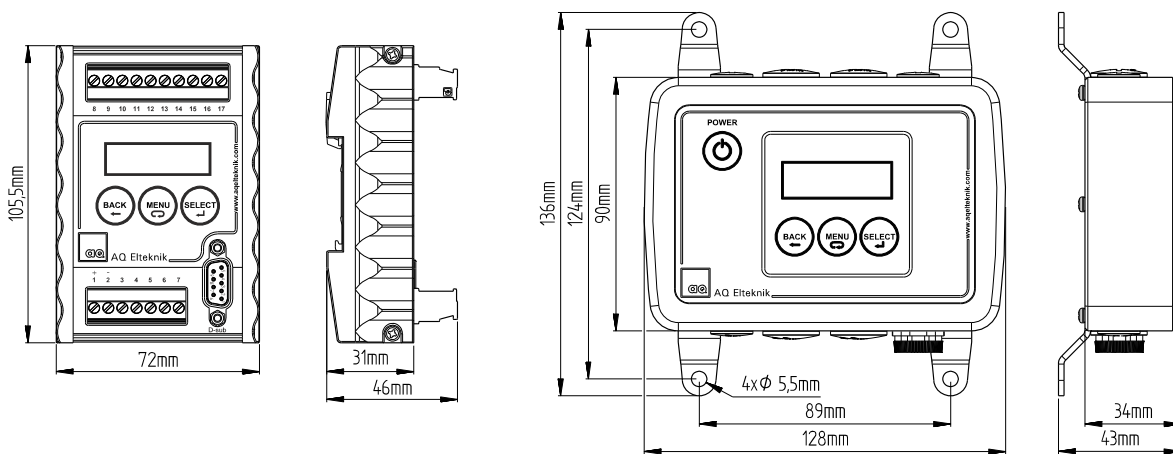

Motor Controller, MP72

Motor Controller MP128