

Ultrasound Controller DP36

Level Switch PSF

Manual

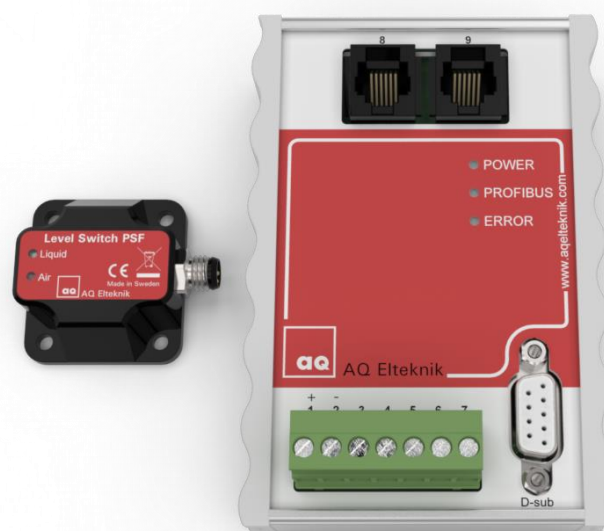

Ultrasound Controller DP36 Level Switch PSF Manual

- **Manual** **Rev 2.9**
- **DP36** **Rev G**
- **Gsd file DP360E68.gsd** **Rev 1.1**
- **Software Version** **2.5 and 2.6**

December 2022

AQ M-Tech AB



Table of contents

1. Manufacturer information	5
Rev.....	5
Manufacturer Declaration of Conformity.....	5
Limited Warranty	5
Warning.....	5
Manufacturer Information	5
Certificate of Quality and Function	5
2. Introduction.....	6
Ultrasound Controller DP36	6
Installing the Ultrasound Controller DP36	6
3. Level Switch PSF	7
Quick start guide	7
Connecting DP36.....	7
SETTINGS	8
Level Switch Type and Technique	9
Echo Technique	9
WR Technique	9
CALIBRATION.....	10
Sound velocity and the Level Switch.....	10
Factory Restore	10
Indications and Troubleshooting	10
4. Installing the Level Switch PSF	12
5. Profibus DP	13
Connecting Profibus.....	13
Request Data	13
Response Data	13
Request Data table	13
Response Data table.....	14
6. Technical specifications Ultrasound Controller.....	15
7. Technical specifications Level Switch PSF	15

1. Manufacturer information

AQ M-Tech AB operates a policy of on-going development and reserves the right to make changes and improvements to any of the products described in this manual without prior notice.

Under no circumstances shall AQ M-Tech be held responsible for any loss or indirect damage howsoever caused. The contents of this document are provided as it is. AQ M-Tech AB reserves the right to revise this document or withdraw it at any time without prior notice.

Rev

It is important that the manual rev, DP36 rev, gsd file rev and software version all correspond to the information on page 3.

This manual can be downloaded at www.aggroup.com/en/aqm-tech/aq-m-tech

Manufacturer Declaration of Conformity

Manufacturer: AQ M-Tech AB Sweden declares, that the product:

Ultrasound Controller marked with CE-label conforms with the following standards: EN 61000-6-2, EN 61000-6-4 and EN 55011 (Group 1, Class B).

Ultrasound Controller marked with  conforms to WEEE directive 2012/19/EU. The Ultrasound Controller also conforms to RoHS directive (EU) 2015/863. When the Ultrasound Controller is to be discarded, send it back to AQ M-Tech AB for safe disposal.

Limited Warranty

AQ M-Tech AB warrants to the original end user that the Ultrasound Controller is free from any defects in materials or workmanship for a period of one year from the date of purchase. During the warranty period, should the Ultrasound Controller have indications of failure due to faulty workmanship or materials, AQ M-Tech AB will replace it with no charge. This warranty shall not apply if the Ultrasound Controller is modified, misused or subjected to abnormal working conditions.

Replacement as provided under this warranty is the only remedy of the purchaser. The purchaser pays freight to AQ M-Tech AB. AQ M-Tech AB shall in no event be held liable for indirect or consequential damages of any kind or character to the purchaser.

Warning

The Ultrasound Controller is intended to be used with the Level Switch, manufactured by AQ M-Tech AB. AQ M-Tech AB takes no responsibility for any possible damage that could happen if any other sensor not manufactured by AQ M-Tech AB is connected to the Ultrasound Controller.

Manufacturer Information

AQ M-Tech AB

Bolandsgatan 10
SE-753 23 Uppsala
Sweden

www.aggroup.com/en/aqm-tech/aq-m-tech

Phone: +46 184702900

info.aqmtech@aggroup.com

Certificate of Quality and Function

AQ M-Tech AB guaranties that the Ultrasound Controller has passed function tests and quality tests.



2. Introduction

Ultrasound Controller DP36

Ultrasound Controller DP36 uses ultrasound to make measurements. It can detect presence of liquid behind a container wall. The Ultrasound Controller currently has one mode of operation:

Level Switch PSF mode: The Level Switch PSF is a sensor which attached to the outside of a container can sense the presence of liquid inside the container without making hole in the container. Two Level Switch PSF can be connected to one Ultrasound Controller DP36.

Installing the Ultrasound Controller DP36

The Ultrasound Controller DP36 should be protected from dust and water. It is made to be attached to a DIN-rail in a cabinet. It snaps easily to the DIN-rail and it can be removed by pushing up and bending the top out. The green terminal block ① can be removed by pulling the connector straight up. The two RJ12 connectors ② connects to the Level Switches. The D-sub connector ③ connects to profibus.

The Ultrasound Controller DP36 should be installed in accordance with national regulations. A person with the required knowledge should perform the installation.

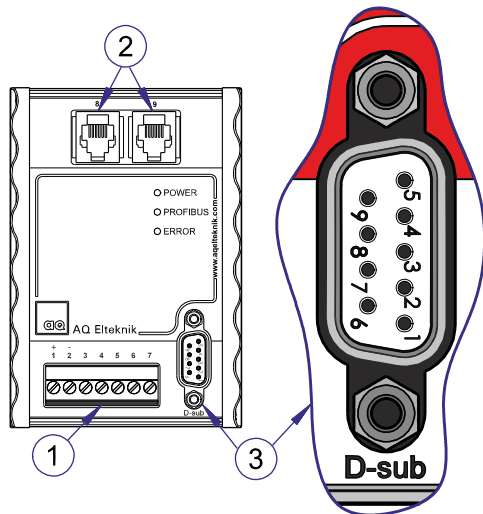

- ① Terminal block
- ② RJ12
- ③ D-sub

③ D-sub	Description
1	Cable screen
2	
3	Profibus B+
4	
5	Minus (GND)
6	+5V
7	
8	Profibus A-
9	

① Terminal block	Description
1	+ Supply PLUS 24V
2	- Supply MINUS
3	Ground
4	NPN 1
5	NPN 2
6	Ground
7	Factory Restore Input

② RJ12	Description
8-1	Level Switch1 (Led+)
8-2	Level Switch1 (Led-)
8-3	Level Switch1 (sensor+)
8-4	Level Switch1 (sensor-)
8-5	GND
8-6	GND
9-1	Level Switch2 (Led+)
9-2	Level Switch2 (Led-)
9-3	Level Switch2 (sensor+)
9-4	Level Switch2 (sensor-)
9-5	GND
9-6	GND

3. Level Switch PSF

The Level Switch PSF measures a single level from the side of the container. It measures the presence or no presence of liquid behind the container wall. The Level Switch senses through the wall and no hole is needed. Two Level Switches can be connected to one Ultrasound Controller DP36.

Quick start guide

- Install Level Switch PSF (page 4)
- Connect cables to power, ground, profibus and Level Switch.
- Switch on the external power supply
- Install the file DB360E68.gsd in the master and make all settings.
- Use a profibus master with ability to change slave address if it must be changed.
- Calibrate with air and with liquid.

Connecting DP36

Connect power supply 24V DC (terminal block 1, 2).

Inside DP36 there is connection between terminal block 2 (power minus) and terminal block 3 (ground).

Connect DP36 terminal block 3 to ground.

NPN-outputs (terminal block 4, 5, 6) can be used instead of profibus.

Leave factory restore input unconnected (terminal block 7 is only used for restore).

Connect profibus to D-sub connector.

The screened cable from the Level Switch should connect directly to the Ultrasound Controller and should be grounded in the cable gland.

Level Switch PSF connector M8

- ① Level Switch (Led+)
- ② Level Switch (Sensor+)
- ③ Level Switch (Led-)
- ④ Level Switch (Sensor-)

(Note, this is not standard numbering of the M8 connector)

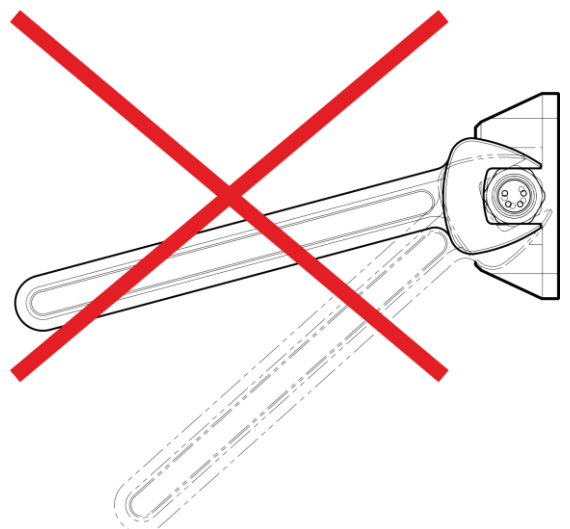
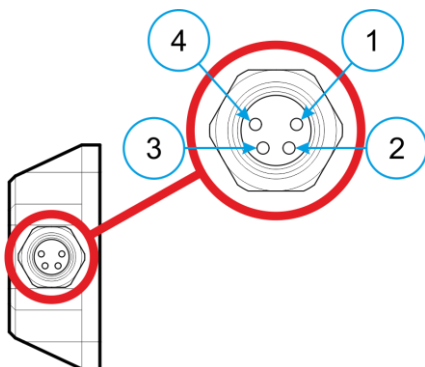

SETTINGS

Settings can be changed via profibus. DP36 is factory restored to default settings below and factory calibrated. DP36 can be used with these settings without profibus on an air trap with inner diameter 85mm to 110mm and using the NPN outputs.

Parameter (LS1, LS2)	Possible values	Factory default
Technique	0 = ECHO 1 = WR	0
Distance to reflecting wall (inner diameter)	0 = 43mm 1 = 46mm 2 = 49mm 3 = 53mm 4 = 58mm 5 = 65mm 6 = 75mm 7 = 85mm 8 = 95mm 9 = 100mm 10 = 115mm 11 = 135mm 12 = 165mm 13 = 200mm 14 = 240mm 15 = 290mm 16 = 340mm 17 = 400mm	8
Filter	0 = 0,3s 1 = 0,5s 2 = 1s 3 = 2s 4 = 4s	2
Wall type	0 = Plastic PP 1 = Plastic PEEK 2 = Plastic 3 = Glass 4 = Metal	0
Wall thickness	0 = 2mm 1 = 4mm 2 = 6mm 3 = 9mm 4 = 12mm 5 = 15mm 6 = 20mm	4
Indication with Liquid	0 = data=0, NPN= open 1 = data=1, NPN= closed	0
Indication with Sensor error	0 = indicates Liquid during error 1 = indicates Air during error	0

Level Switch Type and Technique

There are two different measuring techniques Echo and WR (Wall Reverberate).

Echo Technique

The Echo technique uses echo from a reflecting surface inside the container (usually the opposite container wall) to determine if there is liquid or not inside.

The ECHO-technique transmits ultrasound pulses and then measures the echo bouncing from the reflecting surface. If there is liquid inside there is an echo, and if there is no liquid there is no echo. The liquid must not attenuate the sound too much. Small bubbles and particles in the liquid can cause attenuation and unmixed liquids having different sound velocities can cause refraction of the sound and thereby wrong indication. It is important that the sound-beam from the sensor is reflected back to the sensor and not diverted in a wrong direction.

Ideally the ultrasound should pass as easy as possible through the container wall. How well it passes depend on the ultrasound attenuation of the material. Steel or glass has low attenuation and should be in the range of 1,2mm - 15 mm. Sound attenuation in plastic is dependent on the type of plastic. PEEK has low attenuation and PP has high attenuation which is temperature dependent. Thickness of PP should be maximum 12mm. Testing on the actual container is recommended. Any welding or unevenness in the wall should be avoided as it can refract the sound-beam.

The ultrasound beam behaves similar to a light-beam, the direction of the echo depends on from what angle it hits the reflecting surface. Obstructing object in the path between sensor and the reflecting surface should be avoided. The sound beam is approximately 1cm in diameter. A tube in the center of the container can give an echo but it is weaker than the echo from the opposite container wall.

WR Technique

The WR technique measures vibrations in the container wall to determine if there is liquid or not behind the wall.

The WR-technique transmits sound and then measures how quickly vibrations in the container wall disappear. Vibrations in the wall disappear more quickly with liquid inside. The WR-technique works well with every liquid since the sound does not have to travel through the liquid. But the WR-technique is dependent on the material and thickness of the wall. Plastic wall: 5 - 20mm. For PP the WR technique is not recommended due to large temperature dependence. Plastic with fiberglass may not be possible. Testing on the actual container is recommended. WR technique have higher temperature dependence than the ECHO-technique and depends largely on the wall material and thickness.

The WR-technique measures small signal changes and is therefore sensitive to small movements of the Level Switch. The Level Switch should be glued or attached with screws so that it can not move. The advantage of the WR-technique is it is not dependent of liquid properties, concentration gradients, bubbles and obstructing objects.

CALIBRATION

Calibration should be done after installation. Calibration must be done both for liquid and for air. The order and the time between the calibration of air and liquid is of no importance. It is advisable to calibrate at a temperature close to the expected operating temperature.

A new calibration has to be done if the liquid properties changes significantly since the last calibration. To see how well the Level Switch behaves at different temperatures or with a different liquid the measurement data can be checked.

DP36 is factory calibrated for Echo technique, Level Switch PSF, 95mm inner diameter, 12mm wall thickness and when used on a container with 85mm to 110mm inner diameter it can be tested without connecting to profibus.

Calibration is done by setting Request Data to a nonzero value depending on which calibration to perform. Request Data bit 0 selects calibrate 0=Air or 1=Liquid. Changing the Request Data bit 1 or bit 2 from zero to one starts the calibration for the corresponding Level Switch, see the Profibus data exchange table. Request Data should then be set to zero again. To avoid repetitive calibrations DP36 only start a calibration when Request Data bit 1 or bit 2 changes from zero to one.

Example: To calibrate Level Switch 1 for air	set Request Data = 2, then 0.
To calibrate Level Switch 1 for liquid	set Request Data = 3, then 0.
To calibrate Level Switch 2 for air	set Request Data = 4, then 0.
To calibrate Level Switch 2 for liquid	set Request Data = 5, then 0.

Sound velocity and the Level Switch

If there are two or more liquids with significant different sound velocities and the liquids are not well mixed then the ultrasound will refract as it travels through concentration gradients. This may cause false indication of air with the ECHO-technique. The WR-technique is not affected.

Factory Restore

Follow this procedure to restore all settings to factory settings and factory calibration and the profibus address to 36.

Connect a temporary jumper-cable from terminal block 1 (supply +24V) to terminal block 7 (restore input). Switch on power supply, POWER will flicker. During this flickering disconnect the jumper-cable from terminal block 7. If then ERROR lights constantly red a successful restore has been done. Switch off power and remove the jumper-cable.





Indications and Troubleshooting



Level Switch PSF leds

Blue led indicates air. Green led indicates liquid.

POWER led

POWER normally lights constantly green. If it does not light it means electronics inside DP36 is not active and the reason may be: power supply fault, wrong connection or DP36 internal fault.

PROFIBUS led	Led blink pattern	Description	Possible reason
	Constantly green	Profibus communication is active and data exchange is working correctly.	
	Dark	DP36 do not sense any communication at all.	Faulty or missing connection to the profibus master.
	One green blink	DP36 senses communication but do not understand it or can not adapt to the bitrate.	Profibus cable polarity is wrong. Bitrate is higher than 1,5Mbit/s. Communication is not Profibus
	Two green blinks	DP36 understands the communication but do not receive any attempt to start data exchange with it.	The master does not try to start data exchange or is unaware of the existense of DP36 or uses wrong address.
	Three green blinks	DP36 receives messages addressed to it but proper data exchange has not started.	The master is sending configuration and parameter data which is not correct. Wrong gsd-file.

ERROR led	Led blink pattern	Description	Possible reason
	Dark	No error	
	One red blink and 2s dark	DP36 has recently received faulty profibus data	
	Two red blinks and 2s dark	Level Switch 1 error	The echo-signal with liquid was weaker than approximately -45dB during calibration. Or the difference between signal with air and signal with liquid during calibration was smaller than 10dB. The error remains until a new calibration is done.
	Three red blinks and 2s dark	Level Switch 2 error	Same reasons as for Level Switch 1

4. Installing the Level Switch PSF

There must be a tight ultrasound-connection without any air-gap between the Level Switch and the container. This can be achieved by using glue.

Silicone is heat-resistant and can be used at temperatures above 80°C. A Level Switch glued with silicone is also easy to remove.

The silicone should be a transparent type. It takes a few days to cure. Put some silicone on the container-facing side of the Level Switch and press it on to the container. The silicone should cover any gap between the Level Switch and the container. During the first hours the Level Switch must be held steady in place. The Level Switch can be used even though the silicone is not completely cured.

Hard glues like epoxy and super glue should be avoided if there are large temperature changes.

If the Level Switch can not be glued, a couplant can be used instead. The couplant can be silicone grease, Electrolube HTC or Sonotech Sono 600 or similar. The couplant does not cure so the Level Switch PSF must be held in place by screws. If the Level Switch is removed, the old couplant should be wiped off and new couplant used next time. Put some couplant on the container-facing side of the Level Switch PSF and screw it to the container. The couplant should cover the tiny gap between the Level Switch and the container. See pictures below showing installation on an air trap.

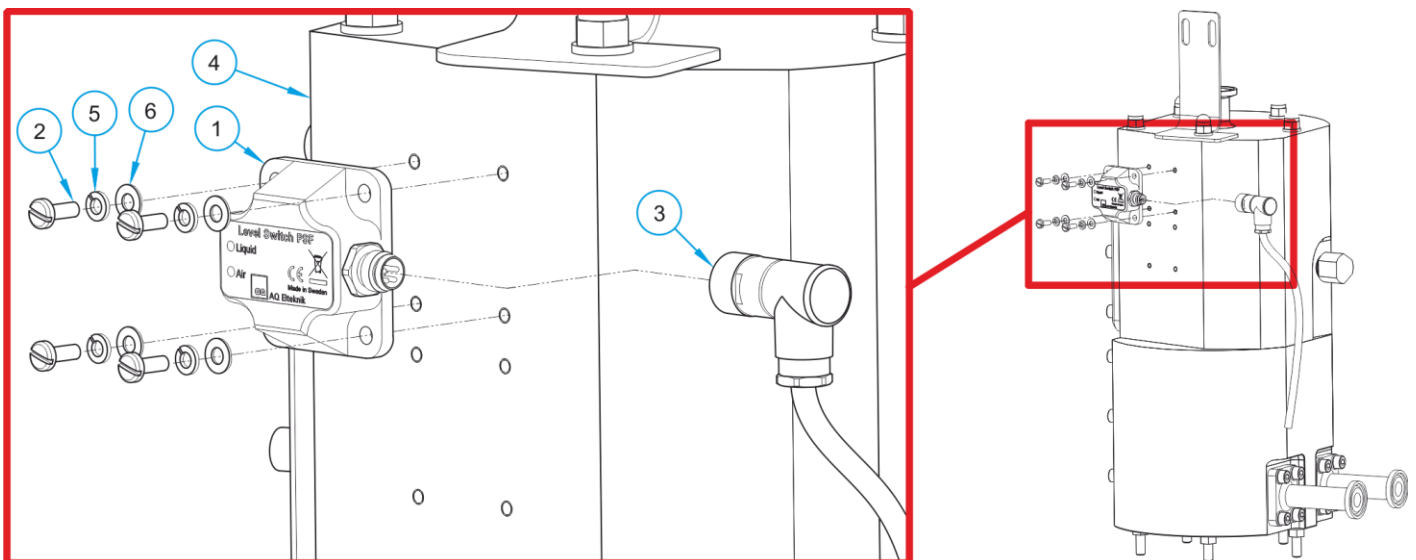

- ① Level Switch LSF
- ② Small screw
- ③ Special cable
- ④ Air trap
- ⑤ Spring washer
- ⑥ Washer
- ⑦ Glue or couplant

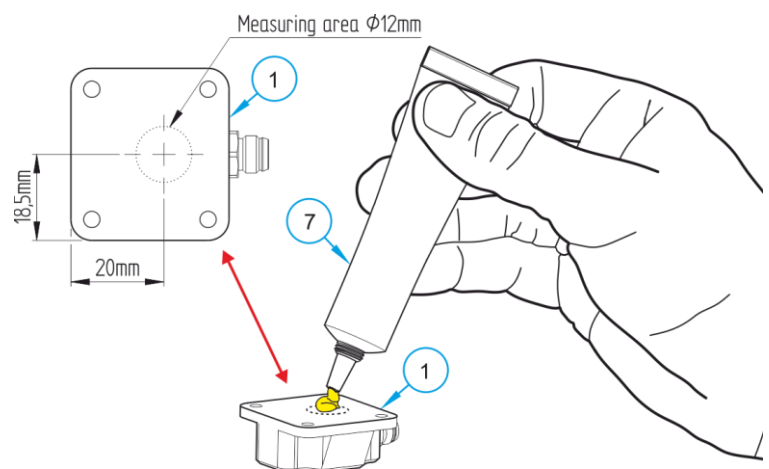

5. Profibus DP

The Ultrasound Controller DP36 supports Profibus DP-V0 with communication speeds up to 1,5Mbit/s.

Connecting Profibus

The Profibus cable connects to DP36 via a 9-pin D-sub connector see table page 6.

If the Profibus cable must be terminated, put 390Ω between pin6 and pin8, 220Ω between pin6 and pin5 and 390Ω between pin3 and pin5.

The Profibus-interface in DP36 is not isolated from ground.

The gsd-file: DP360E68.gsd is needed for configuration of the Profibus master. It can be downloaded at www.aqgroup.com/en/aqm-tech/aq-m-tech, look in "File archive". The revision of the gsd-file is written in the beginning of the gsd-file (the gsd-file can be viewed with a text editor). It must be the correct revision for the DP36 revision. See page 3 for correct revision.

Address is set to 36. To change the address a Profibus master with ability to do so must be used.

Request Data

Profibus master sends one-byte Request Data and DP36 responds with 16 bytes Response Data (1-16). Request data should normally always be zero except during calibration.

Response Data

The format is 8 bit unsigned. Response Data 3 to 16 shows relative signal strength measured in 1/3 dB units (0 is weak and 255 is strong).

Request Data table

Request Data	Level Switch PSF Mode		
	bit0: 0= Air 1= Liquid bit1: 1= calibrate Level Switch 1 bit2: 1= calibrate Level Switch 2 bit3: 0 bit4: 0 bit5: 0 bit6: 0 bit7: 0		

Response Data table

Response Data	Level Switch PSF Mode		
1	Level Switch 1 bit0: 0= Air 1= Liquid bit1: not used bit2: not used bit3: 1= error due to Level Switch 1 not connected bit4: 1= warning weak echo during last calibration of Liquid bit5: 1= error not enough difference between calibration of Air and Liquid bit6: 1= error WR bit7: 1= calibration in progress		
2	Level Switch 2 bit0: 0= Air 1= Liquid bit1: not used bit2: not used bit3: 1= error due to Level Switch 2 not connected bit4: 1= warning weak echo during last calibration of Liquid bit5: 1= error not enough difference between calibration of Air and Liquid bit6: 1= error WR bit7: 1= calibration in progress		
3	Level Switch 1 measured Echo		
4	Level Switch 2 measured Echo		
5	Level Switch 1 measured WR		
6	Level Switch 2 measured WR		
7	Level Switch 1 measured noise		
8	Level Switch 2 measured noise		
9	Level Switch 1 calibrated Echo Air		
10	Level Switch 2 calibrated Echo Air		
11	Level Switch 1 calibrated Echo Liquid		
12	Level Switch 2 calibrated Echo Liquid		
13	Level Switch 1 calibrated WR Air		
14	Level Switch 2 calibrated WR Air		
15	Level Switch 1 calibrated WR Liquid		
16	Level Switch 2 calibrated WR Liquid		

6. Technical specifications Ultrasound Controller

Hardware revision	See page 3
Software version	See page 3
Weight	210g
Operating temperature	0°C to 50°C
Supply voltage	24V ± 3V DC
Current consumption	40mA
NPN1, NPN2	NPN outputs Maximum load: 30V DC 100mA NPN1 is closed when Responedata1 bit0 = 1.
Connectors	Screw terminal, D-sub9, Modular RJ12
Protection class	IP30
Ambient Humidity	0% - 90%
Material	Aluminum, PA, PC
Measurement frequency	1 – 2 MHz
Average output power	<10 mW
Gsd file for DP36	DP360E68.gsd Revision see page 3

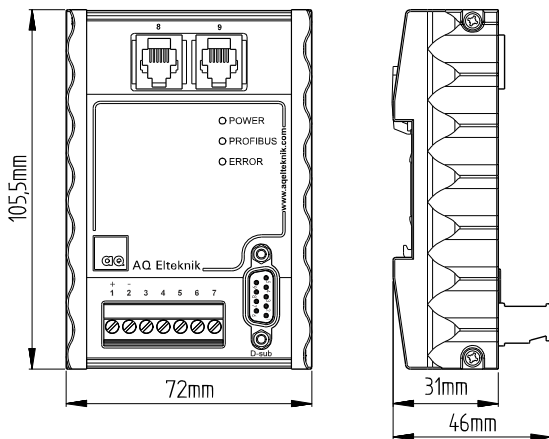

7. Technical specifications Level Switch PSF

Weight	20g
Operating temperature	0°C to 80°C *
Protection class	IP65
Connector	M8
Ambient Humidity	0% - 90%
Material	PET, PC
Cable	screened special cable

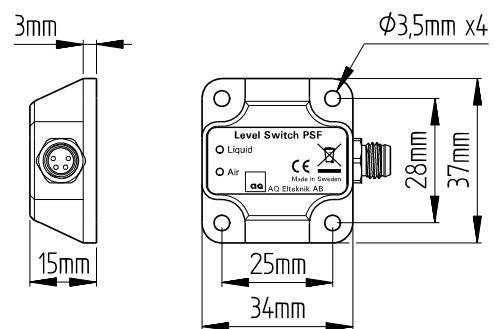

* Container made of PP: ($\leq 12\text{mm}$ wall-thickness) surrounding temperature: 2°C to 35°C and liquid temperature: 4°C to 60°C

* Container made of PEEK: ($\leq 18\text{mm}$ wall-thickness) surrounding temperature: 2°C to 35°C and liquid temperature: 4°C to 80°C

