

Heater Jacket

Model HJSA & HJSB

Manual



Heater Jacket
Model HJSA & HJSB
Manual version 3.6

December 2022

AQ M-Tech AB

Table of contents

1. Manufacturer information.....	4
CE Declaration of conformity.....	4
Limited Warranty.....	4
Warning.....	4
Manufacturer information.....	4
2. Introduction.....	5
3. Installing Heater Jacket.....	5
4. Cleaning.....	5
5. Connections.....	5
6. Technical specification.....	5
7. Material selection.....	5
8. Dismantling the Heater Jacket.....	5
9. Dimensions and weight.....	6
10. Accessories / Spare parts.....	6
11. Fault tracing.....	7
12. Dealer.....	7

1. Manufacturer information

AQ M-Tech AB operates a policy of on-going development and reserves the right to make changes and improvements to any of the products described in this manual without prior notice.

Under no circumstances shall AQ M-Tech AB be held responsible for any loss or indirect damage howsoever caused. The contents of this document are provided as it is. AQ M-Tech AB reserves the right to revise this document or withdraw it at any time without prior notice.

CE Declaration of Conformity

Manufacturer: AQ M-Tech AB Sweden declares, that the product:

Heater Jacket marked with CE-label conforms to the following standards:

EN 61000-6-2, EN 61000-6-4, WEEE Directive 2012/19/EU, RoHS Directive (EU) 2015/863, EN55011 (Group 1, Class B).

Limited Warranty

AQ M-Tech AB (Previously AQ Elteknik AB) gives its end customers a warranty that the Heater Jacket is free from defects in its materials and operation for a period of one year from the date of purchase.

Should the Heater Jacket show signs of manufacturing defects or material defects during the warranty period, AQ M-Tech AB will repair or replace the defective product at no charge.

The warranty becomes void immediately should the Heater Jacket, during the warranty period, in any way be, modified, used incorrectly or be subject to tampering, abnormal working conditions. Such as overheating or used in any other way than what is described in this manual.

The repair or replacement of other equipment in addition to the Heater Jacket can not be provided under the terms of this warranty.

The purchaser pays the carriage charges to AQ M-Tech AB. AQ M-Tech AB can in no way be held liable by the purchaser for damage caused to any other equipment.

Warning

The Heating Jacket may only be connected to one Heater Jacket Control Unit intended for this purpose. Touching the Heater Jacket while in operation should only be done while wearing protective gloves intended for handling hot products.

Flammable or heat sensitive materials must not be found closer than 15 cm from Heater Jacket.

The symbol on the Heater Jacket "Caution!, hot surface" figure 1, means that the surface can be scorching. In order to avoid burn injuries, switch off the Heater Jacket and wait about 30 minutes before touching it.

When extending the Heater Jacket cables only cables supplied by AQ M-Tech AB may be used.

Cleaning may only be carried out when the Heater Jacket is at room temperature.

The Heater Jacket is manufactured with different supply voltages. The supply voltage to the Heater Jacket-Control Unit is governed by the prescribed supply voltage for Heater Jacket. When the supply voltage to the Heater Jacket Control Unit is changed, Heater Jacket must also be changed.

Heater Jacket is not approved for use in Ex-classified environments.

Manufacturer information

Manufacturer: **AQ M-Tech AB**

Address: Bolandsagatan 10
SE-753 23 Uppsala
Sweden

Phone: +46 (0)18-470 29 00

Web: www.aqgroup.com/en/aqm-tech/aq-m-tech

E-mail: info.aqmttech@aqgroup.com



Figure 1

2. Introduction

The Heater Jacket (HJ) is designed for use together with the intended liquid filter or gas filter in industrial environments. All other use it considered to be inappropriate and is done at your own risk.

3. Installing Heater Jacket

Place the HJ over the filter housing

Read the manual for "HJCU", "HJCU-STEEL" or "HJCU-COM" or "HJCU-COM-S"

Connect the HJ to the Heater Jacket Control Unit

The HJ is now operational

4. Cleaning

HJ is cleaned when at room temperature using ethyl alcohol 95% on a soft cloth.

5. Connections

Heater Jacket	Connector type	Connection	Description
Heater	3-way male	pin L & pin N	Supply to Heating element
		pin \ominus	Earth connection
Temp. sensor	2-way male	pin 1	Temperature monitoring A
		pin 2	Temperature monitoring B

6. Technical specification

Type	HJSB	HJSA
Supply voltage	100-120 VAC 50-60 Hz	220-240 VAC 50-60 Hz
Automatic overheating cut-out HJ ¹	155°C	155°C
Maximum application temperature	140°C	140°C
Maximum operating time at 140°C	400h	400h
Temperature range (SV) ²	30°C – 140°C	30°C – 140°C
Normal working temperature	30°C – 100°C	30°C – 100°C
Temperature sensor type	Pt 100	Pt 100
Protection class	IP 65	IP 65
Ambient humidity	10%-90%	10%-90%
Steel material	Stainless acid proof 316L	Stainless acid proof 316L
Plastic material	Polyamide 66	Polyamide 66
Patent no.	0101275-6.	0101275-6.

7. Material selection

All units & cables on the product are /shall be approved according to UL, CSA & CE.

8. Dismantling the Heater Jacket

Recommendations when dismantling the HJ.

Switch off the voltage supply to the HJ and wait about 30 minutes or until the HJ is at room temperature.

Disconnect "Heat" and "Temp" connectors.

The HJ can then be removed from the filter housing.

1. HJ = Heater Jacket, HJSA, HJSB. The HJ is equipped with an automatic resetting, overheating cut-out that trips at 155 °C.
2. SV = Set value. Set working temperature. Shown on the regulator's display. See the manual for the Heater Jacket Control Unit "HJCU".

9. Dimensions and weight

Outside dimensions apply unless otherwise stated. The height is measured from the top section of the top ring to the lower section of the dome nut.

The column filter is an example of a filter housing that matches with each HJ.

Item no.	Filter	Width mm	Height mm	Top ring Id	Weight kg	Power	Supply VAC
HJSA 089 - 572	Advanta 20"	123	572	89	5.0	800	230
HJSB 089 - 572	Advanta 20"	123	572	89	5.0	800	115
HJSA 089 - 318	Advanta 10"	123	318	89	3.0	400	230
HJSB 089 - 318	Advanta 10"	123	318	89	3.0	400	115
HJSA 102 - 274	PLT 10"	136	274	102	2.1	370	230
HJSA 089 - 185	Advanta 5"	123	185	89	1.8	200	230
HJSB 089 - 185	Advanta 5"	123	185	89	1.8	200	115
HJSA 073 - 130	Junior 440	107	130	73	1.4	100	230
HJSB 073 - 130	Junior 440	107	130	73	1.4	100	115
HJSA 104 - 302	Millipore* 10"	138	302	104	1,6	400	230
HJSB 104 - 302	Millipore* 10"	138	302	104	1,6	400	115
HJSA 104 - 155	Millipore* 5"	138	179	104	1,4	200	230
HJSB 104 - 155	Millipore* 5"	138	179	104	1,4	200	115
HJSA 101 – 302	Sartorius Std. 10"	136	302	102	1,6	400	230
HJSA 101 – 162	Sartorius Std. 5"	136	162	102	1,4	200	230
HJSA 076 – 136	Sartorius mini 5"	110	136	76	1,0	150	230

* Series 3000

10. Accessories/ Spare parts

Heater Jacket Control Unit

Item	Model	Size (WxLxH)	Item no.
Heater Jacket Control Unit	230/115 VAC	125x175x100 mm	HJCU
Heater Jacket Control Unit Communication ³	230/115 VAC	125x175x100 mm	HJCU-COM
Heater Jacket Control Unit Current Communic. ⁴	230/115 VAC	125x175x100 mm	HJCU-COM-S
Heater Jacket Control Unit Steel ⁵	230/115 VAC	135x212(224)x117mm	HJCU-STEEL

Supply and alarm connector without cable is included.

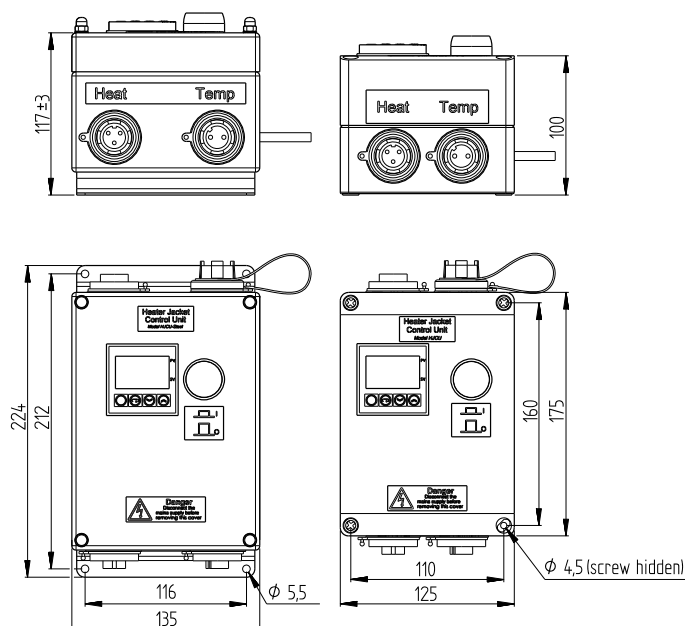

Figure 2

3. Heater Jacket Control Unit Communication – Communicates with RS-485

4. Heater Jacket Control Unit Current Communication - Communicates with 4-20mA DC

5. Heater Jacket Control Unit Steel made of steel 316L, Size In brackets includes mounting angles. See figure 2.

Extension cables and alarm cables

Item	Length	Approval	Type	Item no.
Supply cable Control Unit Sweden	2.0 metres	CEE 7/VII	Y003-B/B	CCUS
Supply cable Control Unit USA/Canada	2.4 metres	UL817, CSA-CC22.2 n 21	TA-3/2,4mG/SVT	CCUU
Extension cable kit Heater Jacket ⁶	2.5 metres	CE, UL, CSA	Silflex, 3G1,0	HJEC-2M
Extension cable kit Heater Jacket ⁶	5.0 metres	CE, UL, CSA	Silflex, 3G1,0	HJEC-5M
Extension cable kit Heater Jacket ⁶	10.0 metres	CE, UL, CSA	Silflex, 3G1,0	HJEC-10M
Alarm Cable Heater Jacket	2.5 metres	CE, UL, CSA	Silflex, 3G1,0	HJAC-2M
Alarm Cable Heater Jacket	5.0 metres	CE, UL, CSA	Silflex, 3G1,0	HJAC-5M
Alarm Cable Heater Jacket	10.0 metres	CE, UL, CSA	Silflex, 3G1,0	HJAC-10M

11. Fault tracing

Problem	Probable cause	Corrective action ⁷
HJ does not become warm	Power switch not pressed in on the HJCU	Press the power switch on the HJCU
	No voltage	Check the incoming voltage
	Blown fuse	Change the main fuse in the HJCU (F1)
	Faulty cable connection HJ	Check the connection
	Short circuit in the HJ	Contact the dealer
	Faulty cable connection Temp	Check the connection
	HJCU or HJ faulty	Contact the dealer
HJ becomes significantly warmer than the set value	Faulty temp element	Contact the dealer
	Faulty overheating cut-out	Contact the dealer
	Faulty HJCU	Contact the dealer

12. Dealer

Dealer: AQ M-Tech AB
Address: Bolandsgatan 10
 SE-753 23 Uppsala
 Sweden
Phone: +46 (0)18-470 29 00

Web: www.aqgroup.com/en/aqm-tech/aq-m-tech
E-mail: info.aqmtech@aqgroup.com

6. Cable kit includes two cables (Temp & Heater cables).

7. The Heater Jacket Control Unit (HJCU) must be disconnected from the main supply when working inside the enclosure.